



# LAMBERTSON INDUSTRIES

HIGH-QUALITY STAINLESS STEEL  
— UNDERMOUNT SINK SCHEMATICS —

## SINGLE COMPARTMENT UNDERMOUNT SINKS

### 16 GAUGE 304 STAINLESS

WITH 3.5" BASKET DRAIN

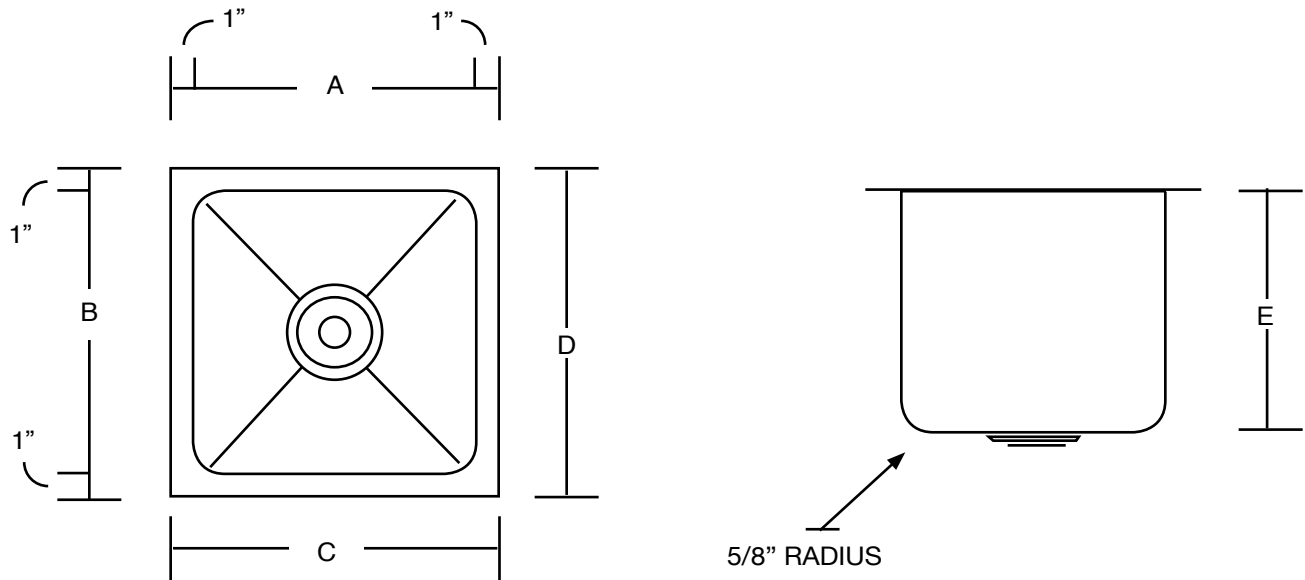

MODEL #	A	B	C	D	E
F1-SST-1717-12-16	17"	17"	19"	19"	12"
F1-SST-1620-12-16	16"	20"	22"	22"	12"
F1-SST-1818-12-16	18"	18"	20"	20"	12"
F1-SST-1723-12-16	17"	23"	22"	25"	12"
F1-SST-1824-12-16	18"	24"	25"	26"	12"
F1-SST-2020-6-16	20"	20"	22"	22"	6"
F1-SST-2020-8-16	20"	20"	22"	22"	8"
F1-SST-2020-12-16	20"	20"	22"	22"	12"
F1-SST-2323-12-16	23"	23"	25"	25"	12"
F1-SST-2424-12-16	24"	24"	26"	26"	12"
F1-SST-2329-12-16	23"	29"	31"	31"	12"
F1-SST-2430-12-16	24"	30"	32"	32"	12"

LAMBERTSON INDUSTRIES • 1335 ALEXANDRIA COURT • SPARKS, NV 89434

PHONE: 775-857-1100 • FAX: 775-857-3289 • TOLL-FREE: 800-548-3324

