



LAMBERTSON INDUSTRIES

HIGH-QUALITY STAINLESS STEEL
UNDERMOUNT SINK SCHEMATICS

DOUBLE COMPARTMENT UNDERMOUNT SINKS 14 GAUGE 304 STAINLESS

WITH 3.5" BASKET DRAIN

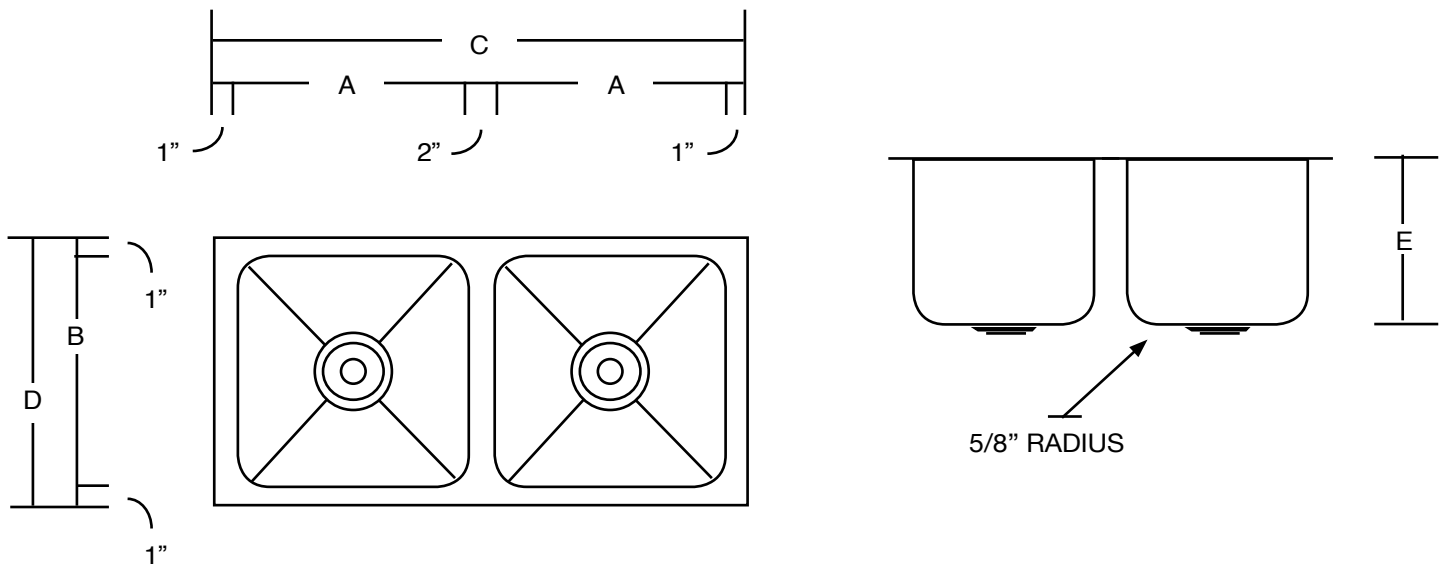

MODEL #	A	B	C	D	E
F2-SST-1717-12-14	17"	17"	38"	19"	12"
F2-SST-1420-12-14	16"	20"	36"	22"	12"
F2-SST-1818-12-14	18"	18"	40"	20"	12"
F2-SST-1723-12-14	17"	23"	38"	25"	12"
F2-SST-1824-12-14	18"	24"	40"	26"	12"
F2-SST-2020-6-14	20"	20"	44"	22"	6"
F2-SST-2020-8-14	20"	20"	44"	22"	8"
F2-SST-2020-12-14	20"	20"	44"	22"	12"
F2-SST-2323-12-14	23"	23"	50"	25"	12"
F2-SST-2424-12-14	24"	24"	52"	26"	12"
F2-SST-2329-12-14	23"	29"	50"	31"	12"
F2-SST-2430-12-14	24"	30"	52"	32"	12"

LAMBERTSON INDUSTRIES • 1335 ALEXANDRIA COURT • SPARKS, NV 89434

PHONE: 775-857-1100 • FAX: 775-857-3289 • TOLL-FREE: 800-548-3324

