

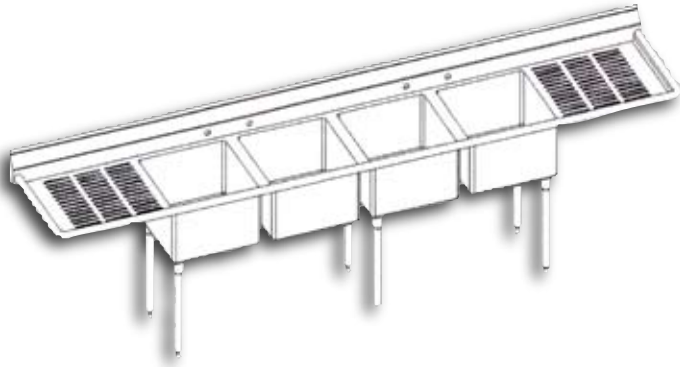

LAMBERTSON INDUSTRIES

H I G H - Q U A L I T Y S T A I N L E S S S T E E L

SPACE SAVER SPEC-LINE SINKS FOUR TUB • TWO DRAIN BOARD



SPECIFICATIONS:

TOPS— 14-gauge, type 304 stainless steel, with integrally formed backsplash and sanitary roll on three sides. Backsplashes are pre-punched for required faucet holes. Drainboards are corrugated die-stamped (CDZ™ Corrugated Dry Zone) and pitched toward the sink. All joints are seam welded and all visible welds are ground smoothed and polished.

TUBS— 14-gauge, type 304 stainless steel with 3-1/2" die-stamped center drain openings. All vertical and horizontal corners minimal 5/8" radius cove. Tubs are integrally welded on tops.

LEGS— Removable 1-5/8" O.D. galvanized iron tubing legs with welded gussets and adjustable sanitary bullet-type feet. **Stainless steel legs and adjustable sanitary bullet-type feet available upon request.**

MECHANICAL:

- Water supply is 1/2" IPS Hot and Cold.
- Faucet holes are on standard 8" centers.
- Faucet height is 36-1/2" from floor.
- Waste drains are 1-1/2" IPS. Stainless Steel. 3-1/2" Basket drains are included.
- All dimensions are typical TOL ± .500

Faucets are not included

FEATURES:

- New **CDZ™ Corrugated Dry Zone**
- All one-piece welded construction
- Radius die-stamped tub bottom for better drainage
- All drainboards have integral backsplashes
- Gussets located on sink and tubs for greater support
- Turned up backsplash
- Tubs with a depth of 10", 12" and 14" are available upon request

CUSTOM SINKS

AVAILABLE UPON REQUEST!

CORRUGATED DRY ZONE™

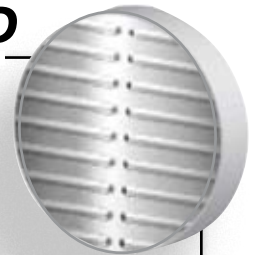

MEETS OR EXCEEDS ALL HEALTH STANDARDS

REDUCES BACTERIA AND ODOR

ALLOWS AIR AND WATER TO FLOW UNDER ALL WASHABLE ITEMS ELIMINATING SUCTION AND CROSS-CONTAMINATION.

LAMBERTSON INDUSTRIES • 1335 ALEXANDRIA COURT • SPARKS, NV 89434

PHONE: 775-857-1100 • FAX: 775-857-3289 • TOLL-FREE: 800-548-3324





LAMBERTSON INDUSTRIES

HIGH-QUALITY STAINLESS STEEL

SPACE SAVER

SPEC-LINE SCHEMATICS

FOUR TUB / TWO DRAINBOARD

14-GAUGE STAINLESS STEEL

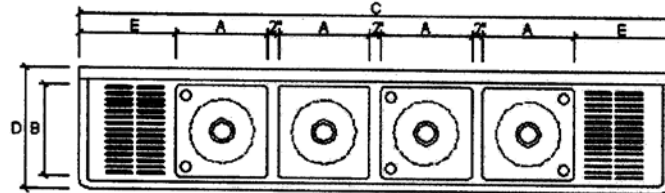
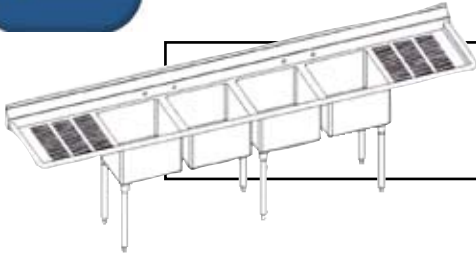

PLAN VIEW

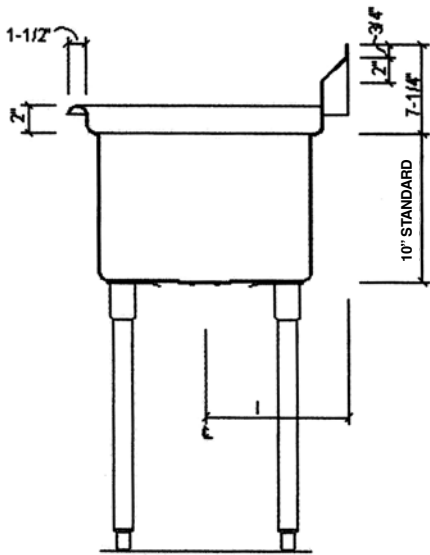

SECTION VIEW

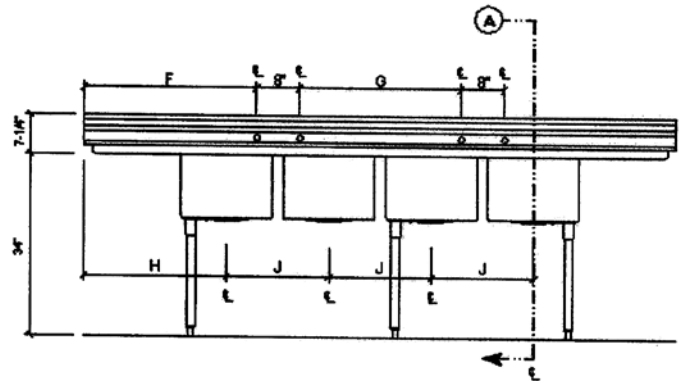

ELEVATION VIEW

SPACE SAVER 4-TUB / TWO DRAINBOARD

MODEL	WEIGHT	A	B	C	D	E	F	G	H	I	J
SS-SL-4-LIN-1014-2D12	160 LBS.	10"	14"	70"	19½"	12"	19"	16"	17"	10"	12"
SS-SL-4-LIN-1014-2D18	165 LBS.	10"	14"	82"	19½"	18"	25"	16"	23"	10"	12"
SS-SL-4-LIN-1517-2D15	175 LBS.	15"	17"	96"	22½"	15"	27"	26"	27"	11½"	17"
SS-SL-4-LIN-1619-2D15	185 LBS.	16"	19"	100"	24½"	15"	28"	28"	28"	12½"	18"

LAMBERTSON INDUSTRIES • 1335 ALEXANDRIA COURT • SPARKS, NV 89434

PHONE: 775-857-1100 • FAX: 775-857-3289 • TOLL-FREE: 800-548-3324

