

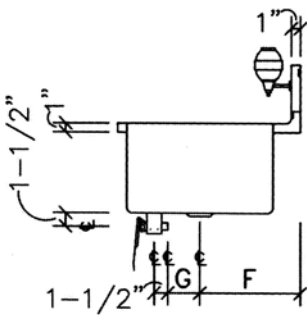

# LAMBERTSON INDUSTRIES

HIGH-QUALITY STAINLESS STEEL  
HAND SINK SCHEMATICS

## HWS SERIES

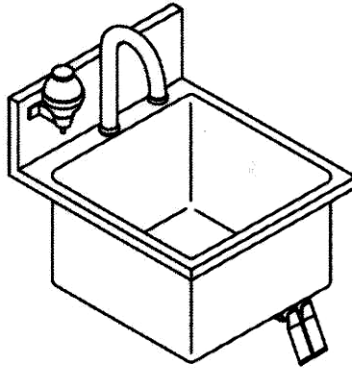

PLAN VIEW

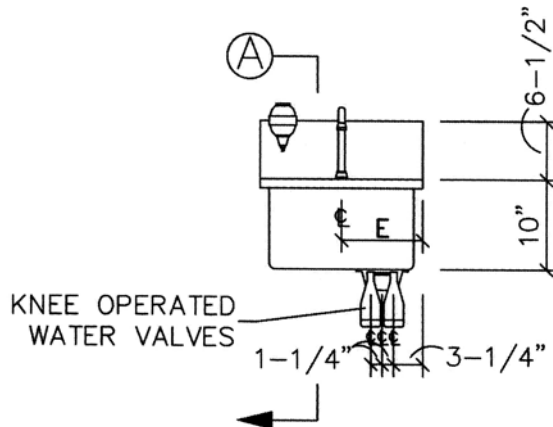

SECTION VIEW

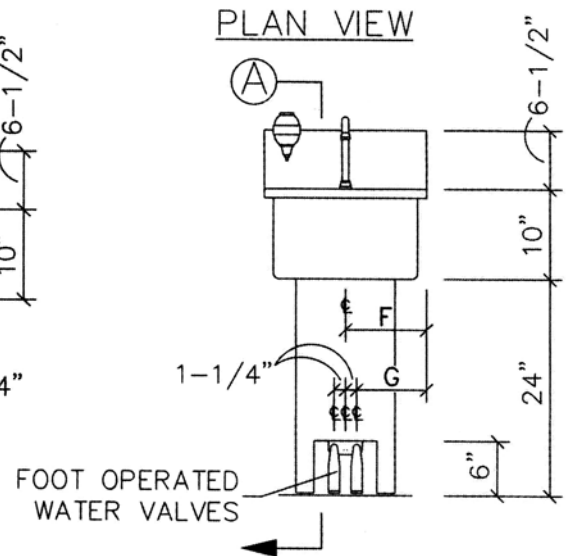

ELEVATION VIEW

MODEL	A	B	C	D	E	F	G	WEIGHT
HWS-16	16"	16"	18"	20"	9"	11"	3-1/2"	25 LBS.
HWS-19	19"	19"	21"	23"	10-1/2"	12-1/2"	5"	30 LBS.

LAMBERTSON STAINLESS STEEL PRODUCTS ARE  APPROVED AND MEET STANDARD #2-DO21814

LAMBERTSON INDUSTRIES • 1335 ALEXANDRIA COURT • SPARKS, NV 89434

PHONE: 775-857-1100 • FAX: 775-857-3289 • TOLL-FREE: 800-548-3324

