

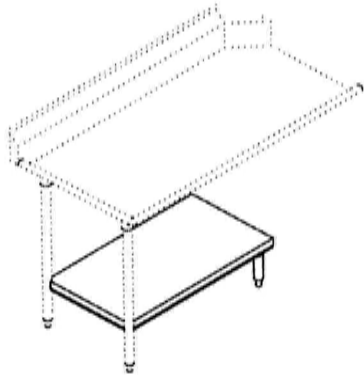

# LAMBERTSON INDUSTRIES

HIGH-QUALITY STAINLESS STEEL

## DISHTABLE SCHEMATICS



### DISHTABLE UNDERSHELVES

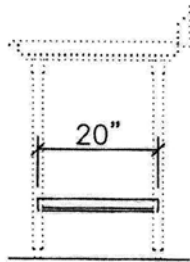

SECTION VIEW

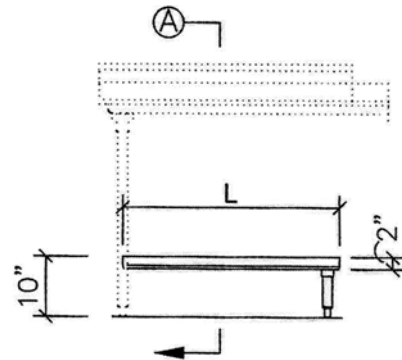

ELEVATION VIEW

MODEL	LENGTH	WEIGHT
DT-UG-2	24"	10 LBS.
DT-UG-3	36"	15 LBS.
DT-UG-4	48"	20 LBS.
DT-UG-5	60"	25 LBS.
DT-UG-6	70"	30 LBS.

#### NOTES

- ▶ SHELF — 16 GAUGE GALVANIZED STEEL CONSTRUCTION WITH TURN TOWN ON ALL SIDES. SHELF IS WELDED TO DISHTABLE LEGS AT ONE END AND SUPPORTED BY 10" HIGH LEGS AT THE OTHER END.

LAMBERTSON INDUSTRIES • 1335 ALEXANDRIA COURT • SPARKS, NV 89434

PHONE: 775-857-1100 • FAX: 775-857-3289 • TOLL-FREE: 800-548-3324

