

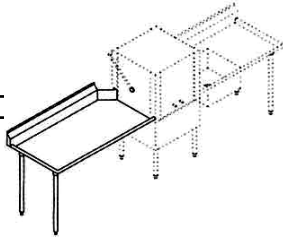

# LAMBERTSON INDUSTRIES

HIGH-QUALITY STAINLESS STEEL  
DISHTABLE SCHEMATICS



## RIGHT TO LEFT CLEAN DISHTABLES • STRAIGHT

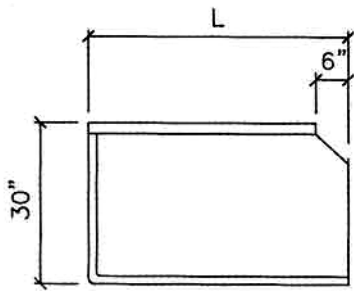

PLAN VIEW

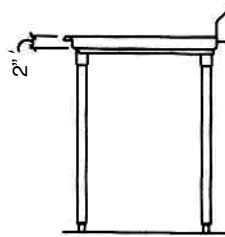

SECTION VIEW

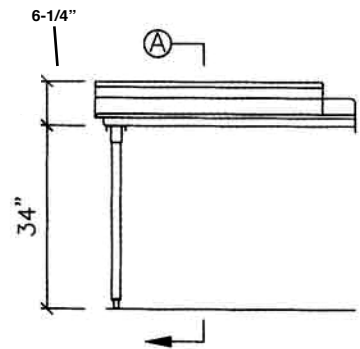

ELEVATION VIEW

MODEL	LENGTH	WEIGHT
DTC-2-RL	24"	30 LBS.
DTC-3-RL	36"	40 LBS.
DTC-4-RL	48"	50 LBS.
DTC-5-RL	60"	60 LBS.
DTC-6-RL	72"	80 LBS.



### NOTES

- ▶ TOP — 16 GAUGE TYPE 304 STAINLESS STEEL WITH INTEGRALLY FORMED BACKSPASH AND SANITARY ROLL ON TWO SIDES.
- ▶ CORRUGATED DRY ZONE SURFACE (FLAT SURFACE TO BE SPECIFIED BY CUSTOMER)
- ▶ OPENING FOR DISHMACHINE (CUSTOMER TO SPECIFY MAKE AND MODEL NUMBER).
- ▶ LEGS — 1-5/8" O.D. 16 GAUGE GALVANIZED TUBING WITH STAINLESS STEEL LEG GUSSETS AND ADJUSTABLE SANITARY BULLET TYPE FEET.

LAMBERTSON INDUSTRIES • 1335 ALEXANDRIA COURT • SPARKS, NV 89434

PHONE: 775-857-1100 • FAX: 775-857-3289 • TOLL-FREE: 800-548-3324

