

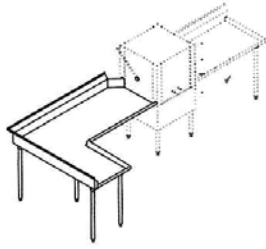

LAMBERTSON INDUSTRIES

HIGH-QUALITY STAINLESS STEEL
DISHTABLE SCHEMATICS



RIGHT TO LEFT CLEAN DISHTABLES • CORNER

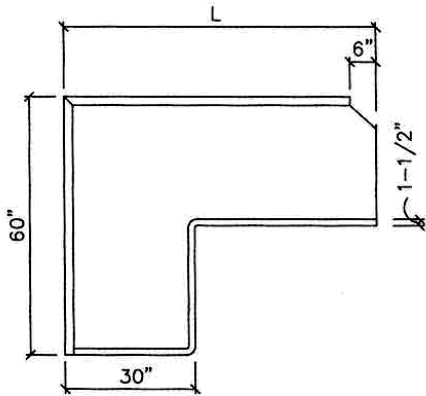

PLAN VIEW

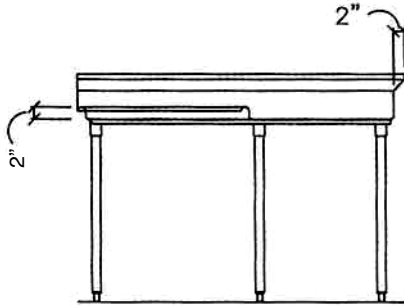

SECTION VIEW

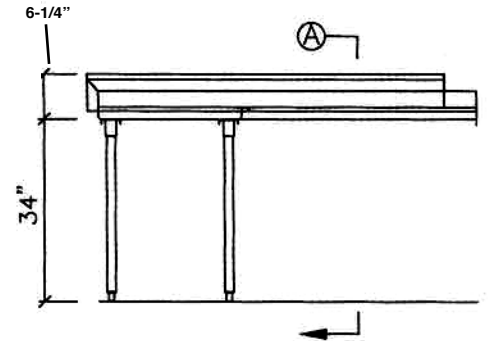

ELEVATION VIEW

MODEL	LENGTH	WEIGHT
CDTC-6-RL	72"	130 LBS.
CDTC-7-RL	84"	140 LBS.
CDTC-8-RL	96"	150 LBS.

NOTES

- ▶ TOP — 16 GAUGE TYPE 304 STAINLESS STEEL WITH INTEGRALLY FORMED BACKSPLASH AT TWO SIDES AND SANITARY ROLL ON THREE SIDES.
- ▶ FLAT TABLE SURFACE
- ▶ OPENING FOR DISHWASHER (CUSTOMER TO SPECIFY MAKE AND MODEL NUMBER).
- ▶ LEGS — 1-5/8" O.D. 16 GAUGE GALVANIZED TUBING WITH STAINLESS STEEL LEG GUSSETS AND ADJUSTABLE SANITARY BULLET TYPE FEET.

LAMBERTSON INDUSTRIES • 1335 ALEXANDRIA COURT • SPARKS, NV 89434

PHONE: 775-857-1100 • FAX: 775-857-3289 • TOLL-FREE: 800-548-3324

